

# STATIONARY DUMPER

1,000/2,000/4,000/6,000 LBS

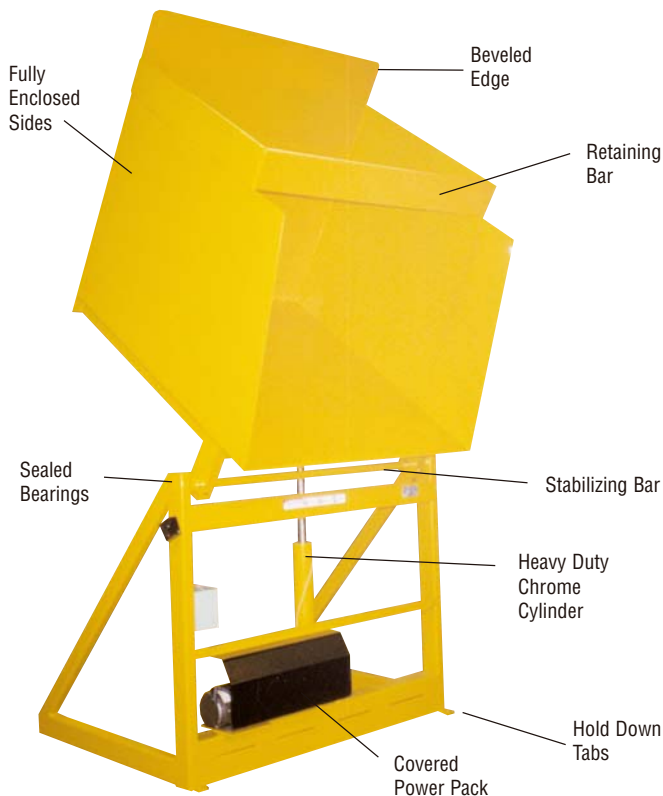
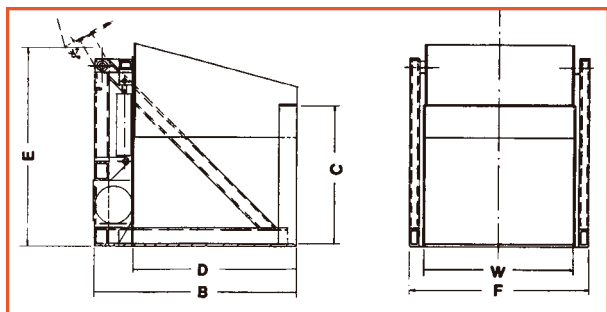

## CAPACITY

- 1,000/2,000/4,000/6,000 lbs.

## BASE SIZES

- 48" wide x 36" long and 50" wide x 50" long

## DUMPING ANGLE

- 0° - 120°

## RETAINING BAR

- Fixed bar - mounted 3" above container height, located above opening
- Spring loaded bar available for multiple container heights (optional)

## SAFETY

- Velocity fuse is standard on each cylinder to eliminate dumpers from collapsing due to hose failure
- Hold down tabs in each corner
- Flow control and pressure equalizing valve built in each pump
- Fully enclosed sides to give the dumper stability, avoid spillage and funnel product

## POWER SUPPLIES

A/C 110/1/60 volt (standard)

- Hand held (standard)
- Foot control (optional)

A/C 220-460-575/3/60 volt

- Hand or foot controlled (optional)

Air/Hydraulic

- Foot control (standard)
- Hand control (optional)

## OPTIONS

- Larger/smaller platform sizes
- Increase/reduce pump height
- Portability
- Limit switchcases
- Special electrical controls
- Chute attachments
- Galvanized, stainless steel, "Steel It" epoxy paint
- Stands for higher dumping applications
- Side guards

## SPECIFICATIONS

MODEL NO.	CAPACITY (LBS.)	PLAT. SIZES (W x D) (IN.)	DUMP HEIGHT (E) (IN.)	TILT ANGLE	R'TEG BAR (C) (IN.)	OVERALL DIM. (F x B) (IN.)
<b>DUMP HEIGHT 36"</b>						
SD 36-10	1,000	48 x 36 50 x 50	36	0 - 120°	UP TO 40	54 x 52 56 x 66
SD 36-20	2,000	48 x 36 50 x 50	36	0 - 120°	UP TO 40	54 x 52 56 x 66
SD 36-40	4,000	48 x 36 50 x 50	36	0 - 120°	UP TO 40	54 x 52 56 x 66
SD 36-60	6,000	48 x 36 50 x 50	36	0 - 120°	UP TO 40	54 x 52 56 x 66
<b>DUMP HEIGHT 48"</b>						
SD 48-10	1,000	48 x 36 50 x 50	48	0 - 120°	UP TO 48	54 x 52 56 x 66
SD 48-20	2,000	48 x 36 50 x 50	48	0 - 120°	UP TO 48	54 x 52 56 x 66
SD 48-40	4,000	48 x 36 50 x 50	48	0 - 120°	UP TO 48	54 x 52 56 x 66
SD 48-60	6,000	48 x 36 50 x 50	48	0 - 120°	UP TO 48	54 x 52 56 x 66
<b>DUMP HEIGHT 60"</b>						
SD 60-10	1,000	48 x 36 50 x 50	60	0 - 120°	UP TO 60	54 x 52 56 x 66
SD 60-20	2,000	48 x 36 50 x 50	60	0 - 120°	UP TO 60	54 x 52 56 x 66
SD 60-40	4,000	48 x 36 50 x 50	60	0 - 120°	UP TO 60	54 x 52 56 x 66
SD 60-60	6,000	48 x 36 50 x 50	60	0 - 120°	UP TO 60	54 x 52 56 x 66

See page 28 for options available.

# STATIONARY DUMPER

1,000/2,000/4,000/6,000 LBS

## OPTIONS



PORTABLE DUMPER  
W/ADJUSTABLE  
RETAINING BAR



PORTABLE DUMPER  
W/NARROW  
DISCHARGE CHUTE



SAFETY GATE  
WITH LOCK OUT



STATIONARY DUMPER  
W/STAINLESS DISCHARGE CHUTE  
& SPECIAL RETAINING SCREEN



STATIONARY DUMPER WITH  
ADJUSTABLE CHUTE ATTACHMENT  
AND SAFETY SKIRTING



PORTABLE FORK  
OVERARM DUMPER



STATIONARY DUMPER  
W/ADJUSTABLE  
RETAINING BAR



PORTABLE STAINLESS STEEL  
"V" MAG DUMPER

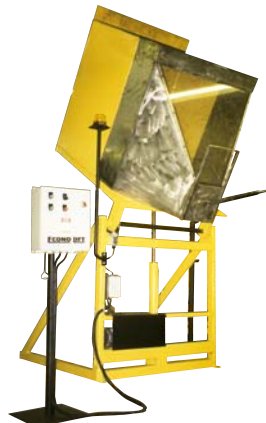

FULLY AUTOMATED DUMPER  
WITH MANUAL OVER RIDE  
AND "E" STOP



STATIONARY DUMPER  
WITH HYDRAULIC GATES



STATIONARY FORK OVERARM  
DUMPER FOR DUMPING  
PORTABLE CONTAINERS



"STEEL-IT" PAINTED FOOD  
GRADE DUMPER



GALVANIZED DUMPER  
WITH STAINLESS CHUTE



STATIONARY CONVEYOR  
DUMPER



WHEELED CART DUMPER



PORTABLE CONVEYOR  
DUMPER WITH CHUTE



PORTABLE SIDE LOADING DUMPER  
WITH STAINLESS STEEL CHUTE