

DRIVE-ON TILT TABLE

1,000/2,000/4,000 LBS

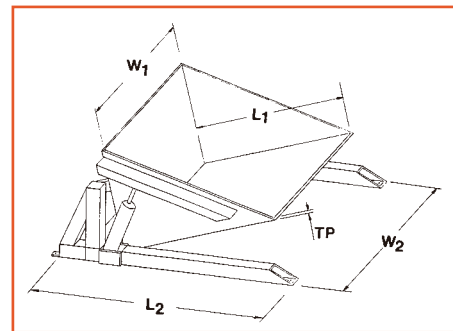

TILT ANGLE

- 0-45°

SAFETY

- Velocity fuse on each cylinder to eliminate tables from collapsing due to hose failure.
- Hold down tabs on all four corners.

LOWERED HEIGHT OF TABLE

- Floor level

POWER SUPPLIES

A/C 110 volt (standard)

Single phase motor
(hand or foot operated controls available)

A/C 460/575 volt (optional)

Three phase motors

Air/Hydraulic (standard)

Foot operated

OPTIONS

- Different platform sizes
- Bellow safety skirting
- Limit switches
- Photo Eye
- Semi-portable c/w dolly handle

OPTIONS



FLOOR LEVEL DUMPER



PORTABLE OPTION

MODEL NO.	CAPACITY (Lbs.)	PLATFORM SIZE W ₁ x L ₁ (in.)	LOW'D HEIGHT TP (in.)	TILT ANGLE (degrees)	OVERALL SIZE W ₂ x L ₂ (in.)
DO-TRT10-4450	1,000	44 x 50	3/8	45	50 x 54
DO-TRT20-4450	2,000	44 x 50	3/8	45	50 x 54
DO-TRT40-4450	4,000	44 x 50	1/2	45	50 x 54
DO-TRT10-5050	1,000	50 x 50	3/8	45	56 x 54
DO-TRT20-5050	2,000	50 x 50	3/8	45	56 x 54
DO-TRT40-5050	4,000	50 x 50	1/2	45	56 x 54