

DRIVE-ON LOADING DOCK

1,000/2,000/4,000 LBS

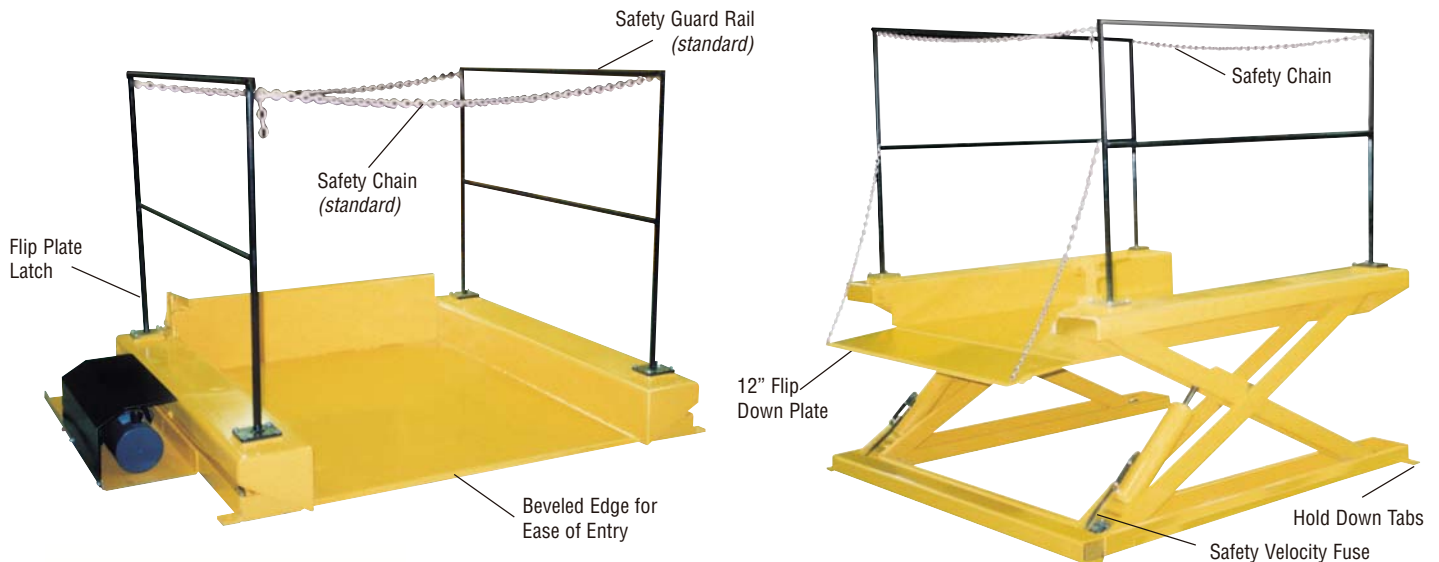

DRIVE-ONS

TRAVEL

- 38", 60"

SAFETY

- Velocity fuse on each cylinder to prevent tables from collapsing due to hose failure.
- Hold down tabs on all four corners.

LOWERED HEIGHT OF TABLE

- Floor level

POWER SUPPLIES

A/C 115 volt, 1H.P. (standard)

- Single phase motor (hand or foot operated controls standard)

A/C 220/460/575 volt, 3 Phase 1H.P. - 5H.P. (optional)

- Three phase motors (optional hand or foot operated controls available)

Air/Hydraulic (standard)

- Foot operated (hand held pendant available)

OPTIONS

- Different platform sizes
- Bellow safety skirting / safety touch bars
- Vertical travel-higher or lower
- Limit switches / photo eyes
- Eye bolts - for moving lifts easily
- Semi-portable c/w dolly handle

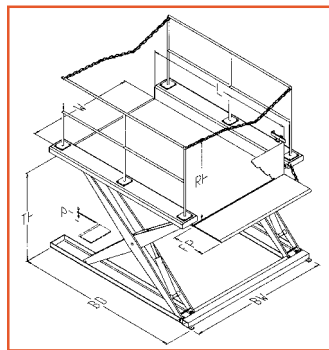

OPTIONS



MODEL NO.	CAPACITY (LBS.)	PLATFORM SIZE W x L (IN.)	FLIP PLATE W x L (FP)	LOW'D HEIGHT (PT)(IN.)	VERTICAL TRAVEL (TH)(IN.)	OVERALL SIZE (BWXBDD)(IN.)	SHIPPING WEIGHT (LBS.)
DO-LD 38-10	1,000	50 x 60	50 x 18	3/8	38	69 x 65	1,000
DO-LD 38-20	2,000	50 x 60	50 x 18	3/8	38	69 x 65	1,200
DO-LD 38-40	4,000	50 x 60	50 x 18	1/2	38	69 x 65	1,400
DO-LD 60-10	1,000	72 x 96	72 x 18	3/8	60	91 x 101	1,600
DO-LD 60-20	2,000	72 x 96	72 x 18	1/2	60	91 x 101	1,800
DO-LD 60-40	4,000	72 x 96	72 x 18	1/2	60	91 x 101	2,000