

DRIVE-ON LIFT/TILT TABLE

1,000/2,000/4,000 LBS

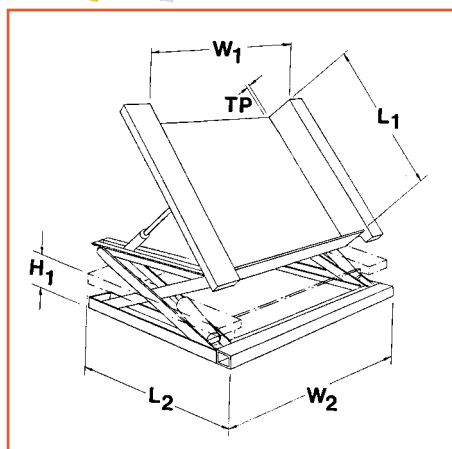
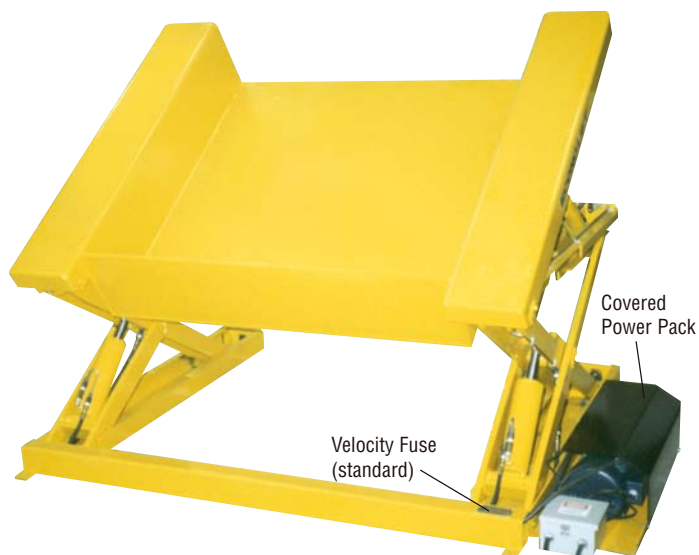

TRAVEL

- 30", 38"

TILT ANGLE

- 0-45°

SAFETY

- Velocity fuse on each cylinder to eliminate tables from collapsing due to hose failure
- Hold down tabs on all four corners

LOWERED HEIGHT OF TABLE

- Floor level

POWER SUPPLIES

A/C 110 volt

Single phase motor
(hand or foot controls
standard draws approx.
15 amps)

A/C 460/575 volt

Three phase motors
(optional)

Air/Hydraulic

Foot operated (Standard)
(hand held pendant optional)

OPTIONS

- Different platform sizes
- Bellow safety skirting / safety touch bars
- Vertical travel - high or lower
- Limit switches / photo eyes
- Eye bolts - for moving lifts easily
- Semi Portable - for moving empty lifts, c/w dolly handle

OPTIONS



MODEL NO.	CAPACITY (LBS.)	PLATFORM SIZE W ₁ x L ₁ (IN.)	LOW'D HEIGHT TP (IN.)	VERTICAL TRAVEL H ₂ (IN.)	OVERALL SIZE W ₂ x L ₂ (IN.)	LOW'D HEIGHT H ₁ (IN.)	OVERALL HEIGHT H ₃ (IN.)
DO-SL/TRT 30-10	1,000	50 x 50	3/8	30	68 x 55	12	42
DO-SL/TRT 30-20	2,000	50 x 50	3/8	30	68 x 55	12	42
DO-SL/TRT 30-40	4,000	50 x 50	1/2	30	68 x 55	12	42
DO-SL/TRT 38-10	1,000	50 x 60	3/8	38	68 x 65	12	50
DO-SL/TRT 38-20	2,000	50 x 60	3/8	38	68 x 65	12	50
DO-SL/TRT 38-40	4,000	50 x 60	1/2	38	68 x 65	12	50

DRIVE-ONS