

# STRADDLE TILTER

2,000/4,000/6,000 LBS

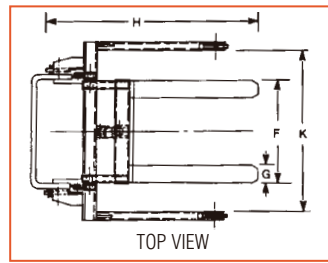
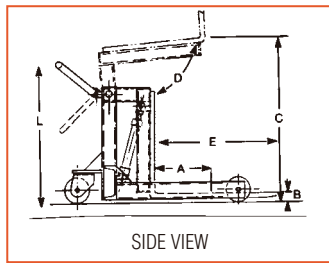
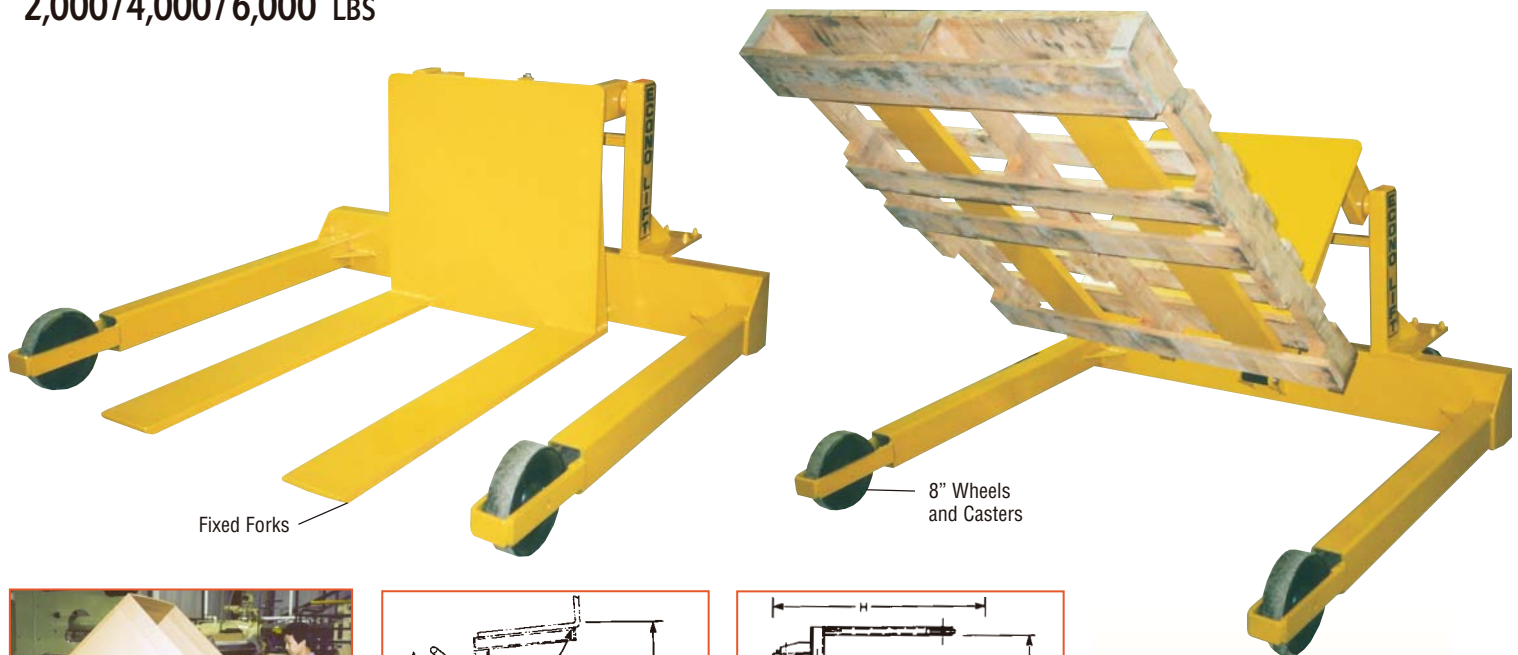

The portable tote box tilter is designed to make the lifting, handling and positioning of small parts containers easy on the worker's back.

Tilts hydraulically to 94°

Makes parts easily reachable  
 - Prevents back strain  
 - Increases productivity.

## OPTIONS

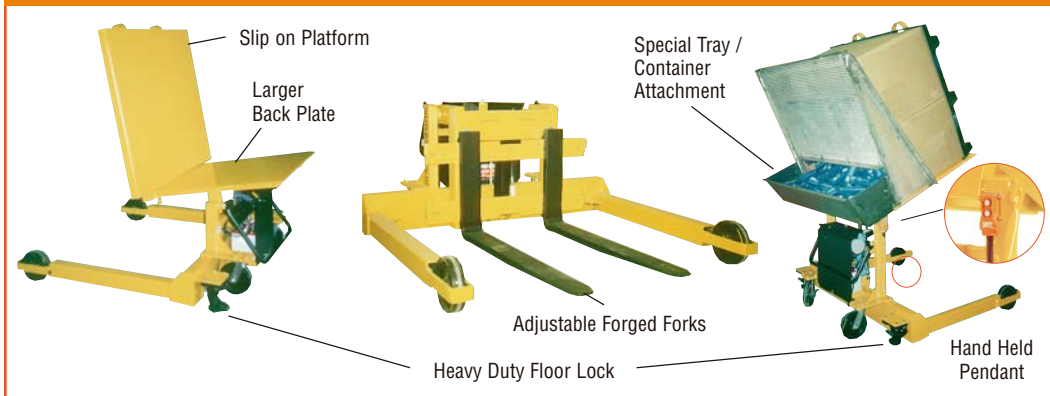

## POWER SUPPLIES

**D/C Battery**  
 Joy Stick Controlled  
**Air/Hydraulic**  
 Foot Pedal  
 (80 p.s.i., 20 c.f.m. min.)  
*hand held pendants optional*

**A/C 115/60/1**  
 Hand Held Pendant



## OPTIONS

- Forks - longer/shorter, higher/ lower to 2", wider / narrower
- Adjustable Forks - 6"-36"
- Slip on Platform
- Tray Attachments
- Larger Back Plates

SPECIFICATIONS		TRS 20	TRS 40 / TRS 60
Capacity	lbs.	2,000	4,000 / 6,000
A Load Centre	in.	21	20
B Lowered Height	in.	2 1/2	2 1/2
C Lift	in.	35 1/2	35 1/2
D Tilt Angle		94°	94°
E Fork Length	in.	42	42
F Fork Width - Fixed	in.	27	27
G Fork Width	in.	4	4
H Overall Length	in.	62	62
K Width	in.	50	50
L Height	in.	27 1/2	27 1/2
Weight	lbs.	650	700
Load Wheels	in.	8	8
Caster	in.	8	8